

# Contents

## *Part 1*

---

### *Introduction* 1-1

- Attaching Power Head to Power Frame 1-1
- Setting the Adjustable Grip Handle 1-2
- Adding Oil to Crankcase 1-2

## *Part 2*

---

### *Operating and Servicing* 2-1

- Operating Instructions and Vibration Adjustment 2-1
- Taking Care of Unexpected Problems 2-2
- Maintenance 2-3

## *Part 3*

---

### *Specifications – Standard Items* 3-1

- Technical and Consumer Information 3-1
- Parts List 3-2
- Front View 3-3
- Back View 3-4
- Warranty 3-5

## *Part 4*

---

### *Specifications – Accessory Items* 4-1

- Options and Accessories 4-1
- Dual Dog 4-1
- Float Pan 4-1
- Strike-Off 4-1

## *Part 5*

---

### *Supplements* 5-1

- Warranty Card Instructions 5-1
- Additional Field Instructions Available 5-2
- Common Replacement Parts for Engines 5-3
- Metal Forms Corporation Quality Inspection Checklist
- Honda Warranty Information Card
- Honda Engine Manual

## INTRODUCTION

### **Attaching the Power Head (Engine) to the Power Frame:**

*Be sure to pay special attention to torque settings.*

<i>Standard Torque Values</i>	
0.118 in. (3 mm) Thread-Diameter Philips Screw	0.7 lb•ft (1 N•m)
0.197 in. (5 mm) Thread-Diameter Philips Screw	3.6 lb•ft (5 N•m)

1. Read the owner's manual before starting or using your Screed unit.
2. Set the Power Frame Unit on a level surface
3. Remove screw A with a phillips screwdriver.
4. Guide the Engine onto the Driveshaft Housing aluminum tube.
5. Orient the mounting hole from screw A with the hole on the driveshaft housing. If you cannot get the holes to align, it is because the driveshaft is not fully seated. Most likely, the splines are not aligned with the engine. Try the following:
  - ✓ wiggle or twist the engine, while pressing onto the driveshaft housing.
  - ✓ turn the eccentric weights by hand, while pressing the engine onto the shaft. You will feel the engine "drop" into position once the splines are lined up.If the holes are not aligned, the engine is not properly seated on the driveshaft, and the driveshaft splines will grind off as soon as the engine is started.
6. Once the engine is seated, re-install screw A on the Engine Mounting Bracket.
7. Securely tighten screw B to 3.6 lb•ft (5 N•m).

**Important: Be sure driveshaft is properly seated into the engine. If the alignment screw (screw A) will not go through the alignment hole, the driveshaft is not fully seated.**

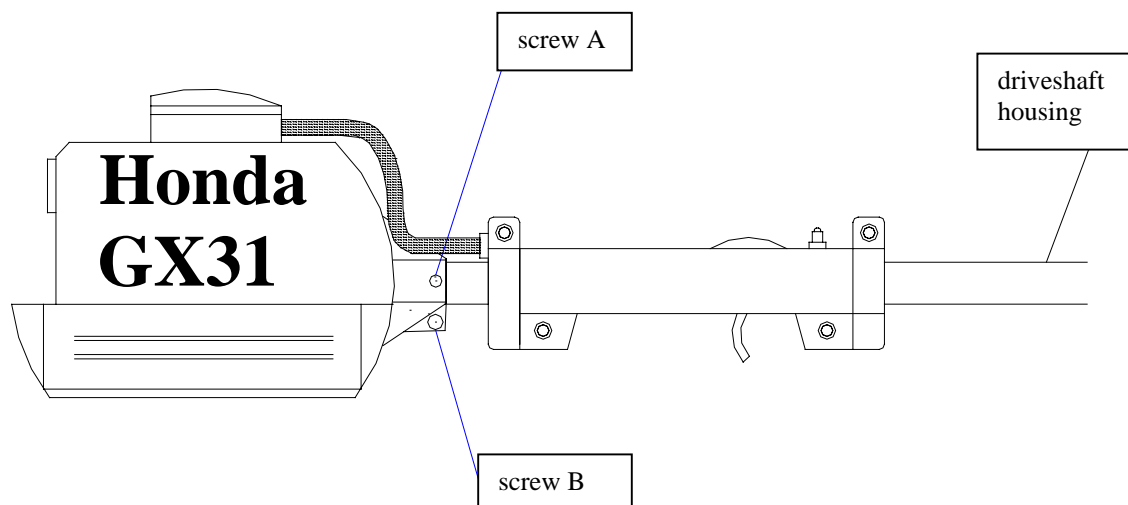

## INTRODUCTION

### **Setting the Adjustable Grip Handle:**

The adjustable grip handle has a positioning range of 180°. Find the operating position which works best for you , and tighten the (2) set screws with a hex (Allen) key. It is recommended to keep the hex key handy when on the jobsite. See Part 3, Front View for detail drawing.

### **Adding Oil to the Crankcase – Initial Use:**

Your SOLO unit is shipped “dry” for safety purposes. Prior to starting your Honda engine, you must add oil to the crankcase. Using the proper type and weight of oil in the crankcase is extremely important. Check the oil before each use and change the oil regularly. Failure to use the correct oil, or using dirty oil, can cause premature engine wear and failure. See the GX31 owner’s manual for more information.

### **Engine Oil Recommendations:**

Oil is a major factor affecting performance and service life. Use 4-stroke automotive detergent oil. SAE 10W-30 is recommended for all temperatures within the recommended operating range. The recommended operating range extends from 23° F (-5° C) to 104° F (40° C).

The SAE oil viscosity and service classification are listed on the API label of the oil container. Honda recommends that you use the API SERVICE category SF or SG oil.

## OPERATING and SERVICING

### Operating Instructions and Vibration Adjustment:

The following are conditions which might require the operator to adjust the amount of vibration:

- 1) Concrete is extremely wet; Too much water being brought to surface.
- 2) Concrete is “raising” (bubbling up) behind the strike-off attachment.
- 3) The pour is narrow; Six (6) feet wide or less.

The counterweight (eccentric weight) is preset at the factory for maximum force of vibration output. Therefore, any adjustment made will decrease the force of vibration. Decreasing engine speed (releasing throttle lever pressure) will decrease the amount of force, as well as the frequency of vibration. If it is deemed necessary to adjust the force of vibration, it can be accomplished by adjusting the counterweight (see steps below).

\*If concrete is “tearing”, or the amount of water near the surface is very low, the operator must slow the rate of travel.

### Adjusting the Counterweight

- 1) Loosen set screw (A) using a 1/8” hex key.
- 2) Rotate counterweight (A) to the desired location; Rotating it 180° will cancel most vibration.
- 3) Tighten set screw (A).

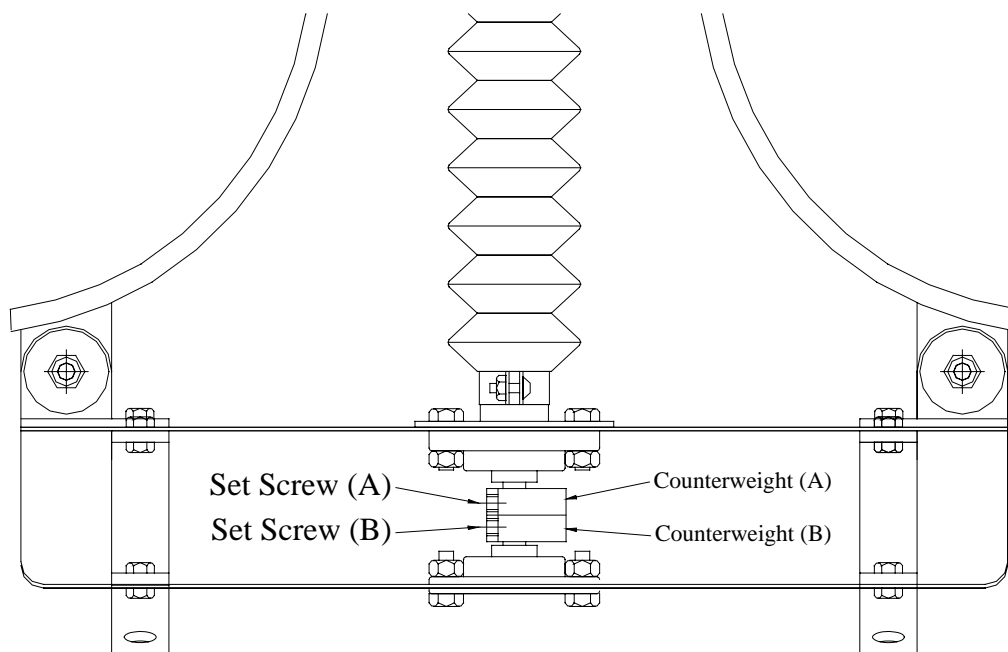



## OPERATING and SERVICING

### Taking Care of Unexpected Problems:

#### Engine Starting Problems

ENGINE WILL NOT START	POSSIBLE CAUSE	CORRECTION
Check control positions	Ignition switch is OFF	Turn ignition switch ON
	Choke not in CLOSED (cold engine) position.	Move choke to the CLOSED position
Check fuel	Out of fuel	Add fuel
	Bad fuel, stored without treating or draining gasoline, refueled with bad gasoline.	Drain fuel tank and carburetor, refuel with fresh gasoline
Remove spark plug	Spark plug faulty, fouled, or has incorrect gap	Clean, gap, or replace the spark plug

#### Engine Operating Problems

LOW POWER OR ENGINE SPEED WON'T INCREASE	POSSIBLE CAUSE	CORRECTION
Check air filter	Filter dirty or clogged	Check, clean or replace air filter
Check fuel filter	Filter dirty or clogged	Replace fuel filter
Check throttle cable	Out of adjustment, broken, or bent	Adjust cable, or replace if necessary
Check spark arrester	Screen clogged	Clean screen

#### Vibration Problems

PROBLEM	POSSIBLE CAUSE	CORRECTION
No Vibration	driveshaft splines stripped, driveshaft broken, or driveshaft not properly seated into engine.	replace driveshaft or properly install driveshaft (see manual MN-02-05 for driveshaft replacement instructions)
Very little vibration	Eccentric weights not properly adjusted	align eccentric weights; ensure set screws are tight.
Excessive vibration in the frame or handlebars.	1. Failed Bearing	Check bearing for metal-to-metal wear. Replace bearing if excessive wear is noted.
	2. Frame cracked	Check welds on frame. Repair if necessary.
	3. Float attachment is loose.	Check bolts securing float attachment to machine. Replace with flanged/serrated head type.

## OPERATING and SERVICING

### **MAINTENANCE:**

Refer to Honda engine owner's manual for exact engine maintenance specifications

#### **A. Before Each Use**

1.	Check engine oil level and quality.
2.	Check air filter.
3.	Check for any loose or missing bolts, nuts, or screws

#### **B. After Each Use**

1.	Clean concrete off bearings, eccentric weights, and engine. Use a brush and clean water.
2.	Check air filter.

#### **C. After first ten hours of use**

1.	Change engine oil.
2.	Check bearing grease.
3.	Check throttle cable tension.
4.	Check torque on nuts, bolts, and fasteners.

#### **D. After every 20 hours**

1.	Remove engine and check driveshaft grease. Grease will have a tendency to be driven down the machine by the rotating shaft.
2.	Check bearing grease and wear.
3.	Check throttle cable tension.
4.	Check screws, nuts, bolts, and other fasteners.
5.	Check for weld failures due to excessive vibration. Repair if necessary.

#### **E. Annually**

1.	<b>Driveshaft:</b> remove engine, aluminum driveshaft housing, and frame weldment. Remove driveshaft from bearings. Check driveshaft splines for wear. Replace driveshaft if necessary.
2.	<b>Driveshaft Liner:</b> Check driveshaft nylon sleeve (inside of aluminum tube) for excessive wear. Replace sleeve if necessary. Repack with driveshaft grease.
3.	<b>Bearings:</b> Remove bearings. Inspect for wear. Perform maintenance or replace as necessary.
4.	<b>Frame Weldment:</b> Check for weld failures due to excessive vibration. Repair if necessary.

#### **Always:**

- ✓ use a thread-locking compound such as Loctite when re-assembling your Solo Unit.
- ✓ use flanged/serrated-head cap screws with lock washers and lock nuts.
- ✓ use proper torque settings based on thread size.

## SPECIFICATIONS – Standard Items

### TECHNICAL & CONSUMER INFORMATION:

<b>ENGINE</b>	
Model	GX31
Engine type	4-stroke, overhead valve, single cylinder
Displacement	1.9 cu-in (31 cc)
Bore & stroke	1.5 x 1.0 in (39 x 26 mm)
Max. output	1.5 hp (1.1 kW) at 7000 rpm
Max. torque	1.23 ft-lbs (1.64 N•m) at 4,500 rpm
Ignition system	Transistorized magneto
Spark plugs	NGK: CR5HSB, DENSO: U16FSR-UB
Starting system	Recoil
Fuel	Unleaded gasoline (86 octane or higher)
Fuel tank capacity	0.69 US qt/22.0 fl. Oz (0.65 litres)
Fuel consumption	0.55 lb/hph (340 g/kWh, 250 g/psh)
Oil capacity	0.11 US qt/3.38 fl. Oz (0.1 litre)
Carburetor type	Diaphragm type (overflow return) with fuel pump
Air cleaner	Single element, semi-dry
Idle speed	3,100 +/-200 rpm
Engine switch	Slide type

## SPECIFICATIONS – Standard Items

**PARTS LIST:** Refer to the drawings on the following pages.

<b>Bill of Materials</b>			
<b>Item No.</b>	<b>Part No.</b>	<b>Description</b>	<b>Qty. req'd per Solo unit</b>
1	185-551	drive shaft	1
2	185-335	adjustable handle w/grip	1
3	040-431	5/16" lock nut	2
	041-125	¼" flat washer	2
4	185-329	frame weldment	1
5	020-422	3/8" x 2-1/4" hex bolt	2
	041-131	5/16" flat washer	2
	040-438	3/8" lock nut	2
6	185-711	vibration unit housing	1
7	028-338	set screw	2
8	040-425	¼" lock nut	2
	040-425	¼" lock washer	
9	185-575	drive shaft housing w/ liner	1
10	048-745	shaft collar	1
	044-309	grommet for shaft collar	3
11	185-733	shaft coupler weldment	1
12	020-491	3/8" serrated/flanged head hex bolt	18
	042-138	3/8" lock washer	18
	040-438	3/8" lock nut	18
13	020-295	¼" hex bolt	2
	042-125	¼" lock washer	4
	040-425	¼" lock nut	2
14	020-394	5/16" hex bolt	1
	042-131	5/16" lock washer	2
	020-431	5/16" lock nut	1
15	185-552	kickstand bracket	1
16	185-707	vibration unit assembly	
17	041-250	vibration washer	2
	185-715	vibration isolation mount	4
18	185-722	attachment bracket	2
19	185-533	kickstand assembly	1
20	044-101	¼" U-bolt	1
21	044-136	5/16" U-bolt	1
	185-520	vibration isolation grommet	1
22	185-740	eccentric weight	2
	028-238	set screw	2
23	185-730	bearing	2
24	185-760	access plate	1

# SPECIFICATIONS - Standard Items

## Front View

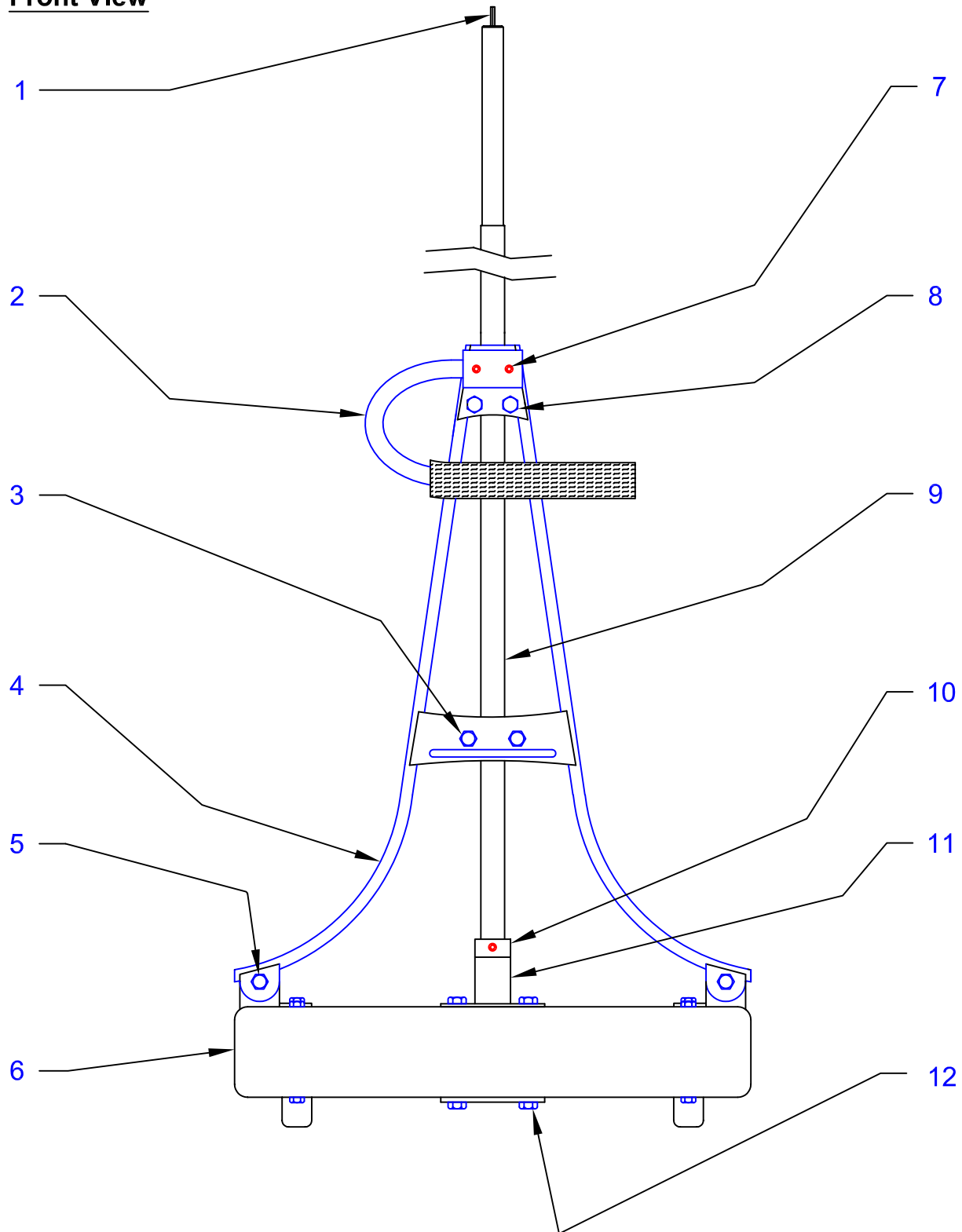

# SPECIFICATIONS - Standard Items

## Back View

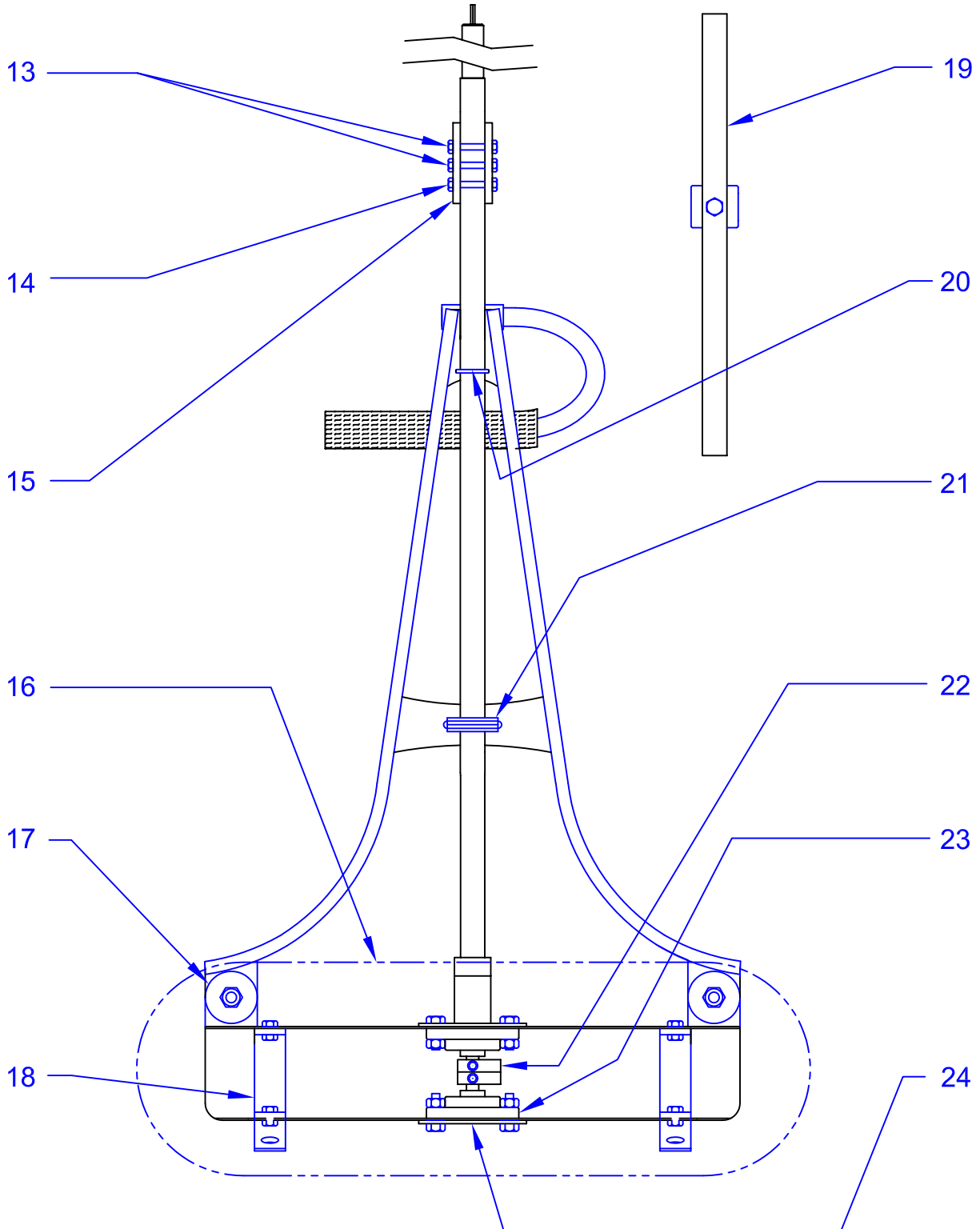

## **SPECIFICATIONS – Standard Items**

### **Warranty**

Metal Forms Corporation warrants, solely to the original purchaser, its products to be free on the date of delivery from defects in material and workmanship. Metal Forms Corporation's obligation under this warranty is conditioned upon Metal Forms Corporation receiving notice of the defect within ten (10) days of discovery, and shall be limited to repairing or replacing, at its option, at its factory, any part or parts, which shall be returned to it with transportation charges prepaid, and which its examination shall disclose, to its satisfaction, to have been thus defective: PROVIDED that this limited warranty shall be effective only if such part or parts shall be so returned to Metal Forms Corporation not later than ninety (90) days after initial delivery of the products to the original purchaser. Metal Forms Corporation neither assumes or authorizes any other person or entity to assume for Metal Forms Corporation any other liability in connection with the sale of the products. No waiver, alteration, or modification of the foregoing conditions shall be valid unless made in writing, and signed by an executive officer of Metal Forms Corporation.

This warranty shall not apply in the event the products shall have been repaired or altered outside of Metal Forms Corporation, or if the products have been subject to abuse, misuse, negligence, or accident.

THE FOREGOING EXPRESS WARRANTY IS EXCLUSIVE AND IN LIEU OF ALL OTHER WARRANTIES EXPRESSED, IMPLIED OR STATUTORY, INCLUDING BUT NOT LIMITED TO THE WARRANTIES OF MERCHANTABILITY AND FITNESS FOR ANY PARTICULAR PURPOSE AND ALL OTHER OBLIGATIONS OR LIABILITIES ON OUR PART. BUYER ACKNOWLEDGES THAT THERE ARE NO WARRANTIES THAT WILL EXTEND BEYOND THE DESCRIPTION ON THE FACE HEREOF, UNLESS IN WRITING AND SIGNED BY BOTH SELLER AND PURCHASER.

The Buyer acknowledges that (s)he is not relying on Metal Forms Corporation's skill or judgment to select or furnish machines or equipment suitable for any particular purpose.

METAL FORMS CORPORATION MAKES NO WARRANTIES OR REPRESENTATIONS AND ASSUMES NO RESPONSIBILITIES IN RESPECT TO PARTS OR COMPONENTS NOT MANUFACTURED BY METAL FORMS CORPORATION.

**NOTWITHSTANDING THE PROVISIONS OF ANY APPLICABLE STATUE, THE REMEDIES AVAILABLE TO THE BUYER AS SET FORTH IN THIS AGREEMENT, ARE EXCLUSIVE REDEDIES, AND ALL OTHER REMEDIES, STATUTORY OR OTHERWISE, ARE HEREBY EXPRESSLY WAIVED BY THE BUYER. METAL FORMS CORPORATION SHALL NOT BE RESPONSIBLE FOR INCIDENTAL OR CONSEQUENTIAL DAMAGES ARISING OUT OF THIS WARRANTY OR BREACH THEREOF.**

## SPECIFICATIONS - ACCESSORY ITEMS

### OPTIONS and ACCESSORIES:

**Tool Kit: P/N 195-851**

INCLUDES SPARK PLUG AND HANDLE FOR HONDA GX31.

**SHOULDER HARNESS:**

195-855: HARNESS  
195-862: HANGER CLIP

**"DUAL DOG":**

REVERSIBLE ALUMINUM SCREED BAR ATTACHMENT  
AVAILABLE IN 8 FT., 10 FT., 12 FT., OR 16 FT. WIDE. 16-FOOT  
WIDE REQUIRES 2 POWER UNITS. WEIGHT: 2.1 LBS. PER FT.

DUAL DOG CROSS-SECTION:  
2-1/2" TALL X 5" WIDE

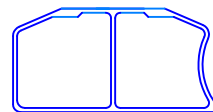

**ALUMINUM FLOAT PAN:**

AVAILABLE IN SIZES 8 FT., 10 FT., OR 12 FT. WIDE. WEIGHT: 1  
LB. PER FOOT.

FLOAT PAN CROSS SECTION  
2-1/2" TALL X 5" WIDE.



**ALUMINUM STRIKE-OFF  
TUBE:**

AVAILABLE IN VARIABLE LENGTHS UP TO 12 FT. WEIGHT: 1  
LB. PER FT.

STRIKE-OFF CROSS-SECTION  
2" X 2" SQUARE



## SUPPLEMENTS

### **Warranty Card Instructions :**

We have included a Warranty Activation Card with your Speed Screed Unit. It should be attached to the engine. In order to activate your warranty, you must submit the requested purchaser information to Metal Forms Corporation. If you are missing your Warranty Activation Card, use the one at the bottom of this page. You may fax it in, call it in, or mail it in.

FAX: 414-964-4550

PHONE: 414-964-4550

MAIL: 3334 North Booth Street, Milwaukee, WI 53212

- ✓ WE MAY NOT BE ABLE TO GRANT WARRANTY CLAIMS IF THE ACTIVATION IS NOT ON FILE.

### **Warranty Activation Card**

Company Name: \_\_\_\_\_

Company Address: \_\_\_\_\_

Date of Purchase: \_\_\_\_\_

Name of Dealer: \_\_\_\_\_

Serial #: \_\_\_\_\_

## SUPPLEMENTS

**Additional Field Instructions Available :**

The following instructions are available for immediate faxing to your location. Call us at (PHONE) 414-964-4550 or FAX: 414-964-4550.

	Instruction #	Title	Abstract
<input checked="" type="checkbox"/>	MN-02-04	Quick-release mounting kit instruction sheet.	<i>A quick-release fasteners kit is available for attaching float pans, Dual Dogs, aluminum strike-offs, and 2x4's to your Solo unit.</i>
<input type="checkbox"/>	MN-02-05	Honda-powered driveshaft assembly.	Instructions on replacing the drive shaft on your Honda-powered Solo unit. Includes sequence of disassembly and re-assembly.
<input type="checkbox"/>	MN-02-07	Float mounting plate retrofit installation.	The current float pans include reinforcement steel plates which significantly extend the life of the aluminum float pan. Any float pan can be retrofitted with our <i>Float Pan Retrofit Kit</i> .
<input type="checkbox"/>	MN-02-13	Vibration isolation conversion kit.	Installation and conversion instructions for replacing the obsoleted bellows design, with the improved shaft-collar design.

## SUPPLEMENTS

### Most Common Replacement Parts for Engines :

The following parts are available for shipping to your location. Call us at 414-964-4550 or FAX: 414-964-4550.

#### FOR 1.5 H.P. HONDA GX31

√	Part #	Description	Qty. Required
<input type="checkbox"/>	185-104	Power Head Assembly (engine only)	1
<input type="checkbox"/>	039-500	spark plug, NGK #CR5HSB	1
<input type="checkbox"/>	195-108	dip stick oil cap #15620-ZM3-000	1
<input type="checkbox"/>	195-109	gasket for oil cap #15625-ZE1-003	1
<input type="checkbox"/>	195-301	recoil assy. #28400-AM3-003Za	1
<input type="checkbox"/>	195-111	screws for recoil assy.	4
<input type="checkbox"/>	195-350	clutch assy. #22000-ZM5-003	1
<input type="checkbox"/>	195-353	Fan (clutch) cover (silver cover) #19600-VF9-700ZB	1
<input type="checkbox"/>	195-354	Fan (clutch) cover assy. #19611-VF9-700ZB (includes silver clutch cover, outer splined clutch, rubber engine mount, engine mounting bracket, & mounting screws)	1
<input type="checkbox"/>	195-425	Carburetor insulator (black plastic) #16211-ZM3-000	1
<input type="checkbox"/>	195-501	Air filter #17211-ZM3-000	1
<input type="checkbox"/>	195-502	Air filter housing #17220-ZM3-000ZA	1
<input type="checkbox"/>	195-503	Air filter cover (plastic snap-in) #17231-ZM3-000ZA	1
<input type="checkbox"/>	195-651	Fuel tank #17511-ZM5-003	1
<input type="checkbox"/>	195-659	Fuel tube, long #17701-ZM3-003	1
<input type="checkbox"/>	195-660	Fuel tube, short #17702-ZM3-003	1
<input type="checkbox"/>	195-657	Fuel Tank Cap #17620-ZM3-023	1
<input type="checkbox"/>	195-703	Flywheel #31110-ZM5-013	1
<input type="checkbox"/>	195-700	Coil Assy., ignition (inc's spark plug wire) #30500-ZM3-003	1
<input type="checkbox"/>	195-750	Cover, top (bright red plastic) #19720-ZM3-00ZA	1
<input type="checkbox"/>	195-900	throttle lever assy. #17850-VF9-B11 (includes wire harness and throttle lever)	1
<input type="checkbox"/>	195-901	throttle trigger #17851-VF9-A11	1