



METAL FORMS CORPORATION
SINCE 1909

BARRIER & PARAPET FORMS



BARRIER & PARAPET FORMS

TYPICAL DOUBLE CONTOUR SET-UP

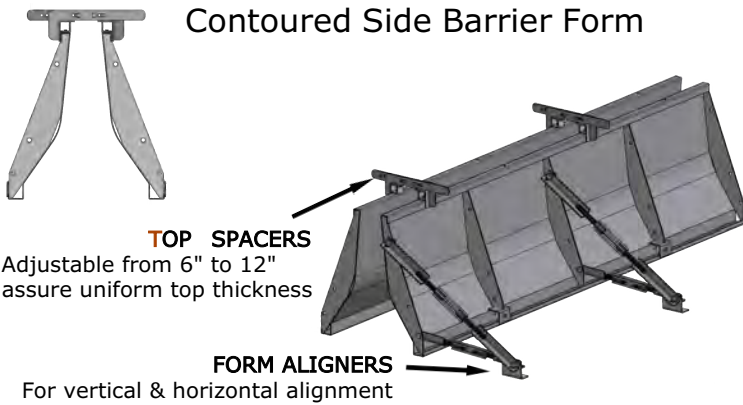

GENERAL FORM PROFILES

Drawing example outlines all specs required for all shapes

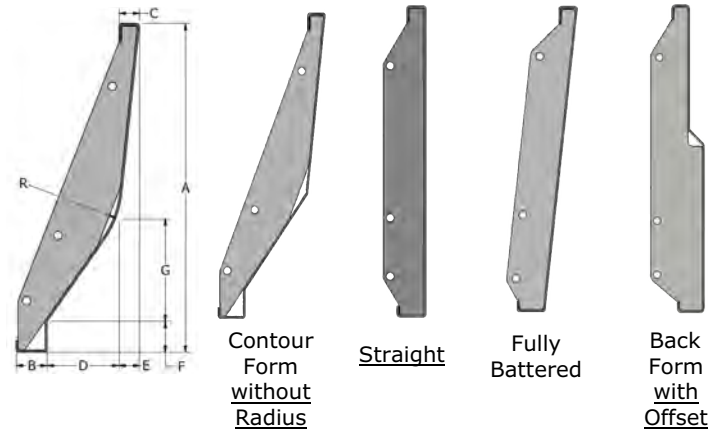

TYPICAL SINGLE CONTOUR SET-UP

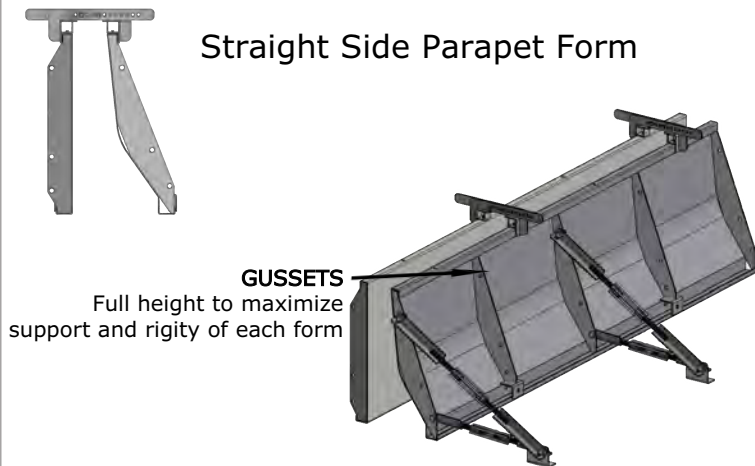

Options

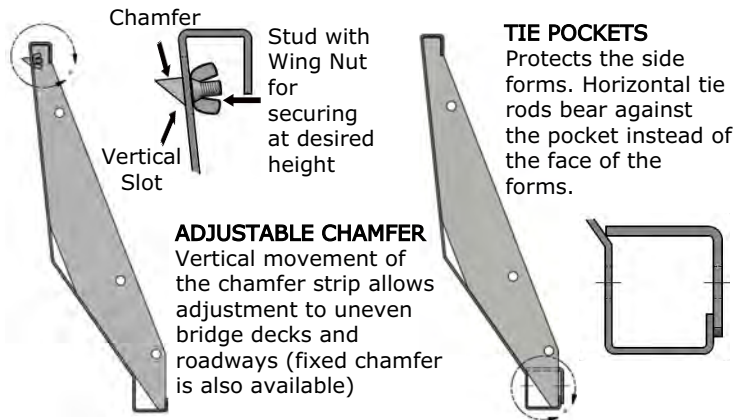

HARDWARE

MOMENT ARMS

Easily adapt from a double contour set-up to a single contour set-up with a straight back

*arms can be engineered for a "no-spread/no-tie" system eliminating the need for horizontal ties

COIL BOLTS & NUTS

Quickly attach moment arms to the gussets and provide accurate end alignment

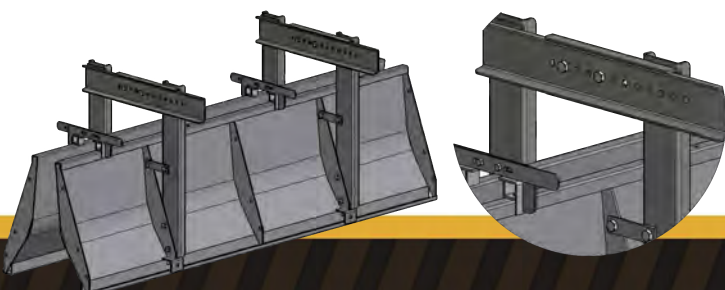

LEVELING BOLT

Convenient method for setting the base of the form to grade

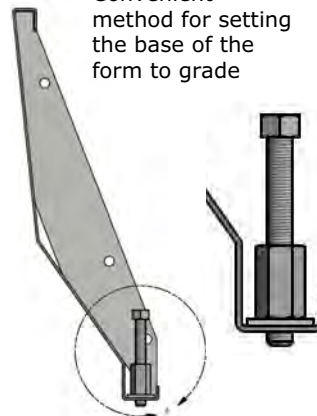

FORM ALIGNER ASSEMBLY

Provides both vertical and horizontal form alignment

